

2.3 Power Dividers

Power dividers are important in signal splitting and combining. An ideal power divider would be matched at all ports, lossless, and reciprocal (so expensive nonreciprocal materials would not be needed in its construction). Is this possible? We can use S-parameters to answer this question.

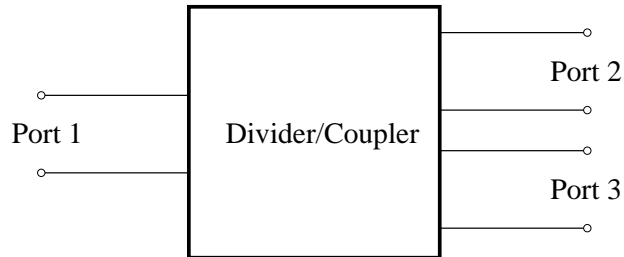

Figure 2.4: Three port microwave network for used as a power divider or coupler (combiner).

Consider a 3-port device with S-matrix

$$[S] = \begin{bmatrix} S_{11} & S_{12} & S_{13} \\ S_{21} & S_{22} & S_{23} \\ S_{31} & S_{32} & S_{33} \end{bmatrix} \quad (2.20)$$

Suppose all three ports are matched so that $S_{ii} = 0$, and that the network is reciprocal so that $S_{ij} = S_{ji}$. The most general possible S-matrix for a device with these properties is

$$[S] = \begin{bmatrix} 0 & S_{12} & S_{13} \\ S_{12} & 0 & S_{23} \\ S_{13} & S_{23} & 0 \end{bmatrix} \quad (2.21)$$

If the network is lossless, then this matrix must be unitary. Using one of the relationships in Section 1.2.3 derived for lossless networks leads to

$$|S_{12}|^2 + |S_{13}|^2 = 1 \quad S_{13}S_{23}^* = 0 \quad (2.22)$$

$$|S_{12}|^2 + |S_{23}|^2 = 1 \quad S_{12}S_{13}^* = 0 \quad (2.23)$$

$$|S_{13}|^2 + |S_{23}|^2 = 1 \quad S_{12}S_{23}^* = 0 \quad (2.24)$$

The second column shows that at least two of the three unique S-parameters must be zero. But if two of them were zero, then one of the equations in the first column would be violated.

From this we can conclude that it is impossible to have a lossless, matched, and reciprocal three port device. Relaxing any one of these constraints makes it possible for the other two constraints to be satisfied. The possibilities are a network that is

1. Lossless and reciprocal, but not matched;
2. Reciprocal and matched but lossy;
3. Matched and lossless using a nonreciprocal material.

2.3.1 Tee Power Divider

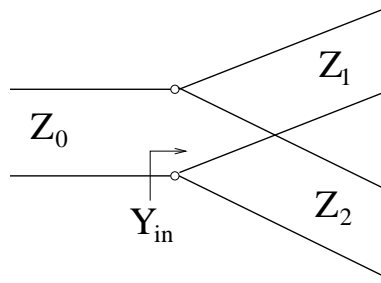

Figure 2.5: Transmission line tee.

The transmission line tee is a three port device that is lossless and reciprocal, but not matched on all ports. From Fig. 2.5, the input admittance is

$$Y_{in} = \frac{1}{Z_1} + \frac{1}{Z_2} \quad (2.25)$$

If we require an input match at port 1, then we must have

$$\frac{1}{Z_1} + \frac{1}{Z_2} = \frac{1}{Z_o} \quad (2.26)$$

If $Z_o = 50 \Omega$, and we choose $Z_1 = Z_2 = 100 \Omega$, $Z_o = 50 \Omega$, then we will have an equal power split (3 dB) and the input will be matched. Because the lines of impedance Z_1 and Z_2 at the other two ports both see an input impedance of 50Ω in parallel with 100Ω , the tee is not matched at the output ports. If we want the impedances of the output lines to be the same as Z_o , we can replace them with impedance matching networks that transform Z_o to the impedances required by (2.26) at the junction. (Does this mean that the tee with matching networks is matched at all ports?)

We can also choose Z_1 and Z_2 for an unequal power split. For example, if we want 5/6 of the power to go down one line and the remaining 1/6 down the other, then we set the two output line impedances to obtain the desired power ratio:

$$\begin{aligned} P_{in} &= \frac{1}{2} \frac{|V_o|^2}{Z_o} \\ P_1 &= \frac{1}{2} \frac{|V_o|^2}{Z_1} = \frac{5}{6} P_{in} = \frac{5}{6} \frac{1}{2} \frac{|V_o|^2}{Z_o} \\ P_2 &= \frac{1}{2} \frac{|V_o|^2}{Z_2} = \frac{1}{6} P_{in} = \frac{1}{6} \frac{1}{2} \frac{|V_o|^2}{Z_o} \\ Z_1 &= \frac{6}{5} Z_o \\ Z_2 &= 6 Z_o \end{aligned} \quad (2.27)$$

where we have assumed that the input is matched so that the incident voltage V_o is the voltage at the junction. This will result in

$$Z_{in} = \frac{1}{5/6 Z_o + 1/6 Z_o} = Z_o \quad (2.28)$$

which is matched. The input impedance seen looking in from the other lines is

$$Z_{in,1} = \frac{1}{1/Z_o + 1/6Z_o} = \frac{6}{7}Z_o \quad (2.29)$$

$$Z_{in,2} = \frac{1}{1/Z_o + 5/6Z_o} = \frac{6}{11}Z_o \quad (2.30)$$

which still represents a mismatch.

2.3.2 Wilkinson Power Divider

The Wilkinson power divider shown in Fig. 2.6 is a three port network that is matched on all ports, but is lossy. The Wilkinson divider also provides output port isolation ($S_{23} = S_{32} = 0$).

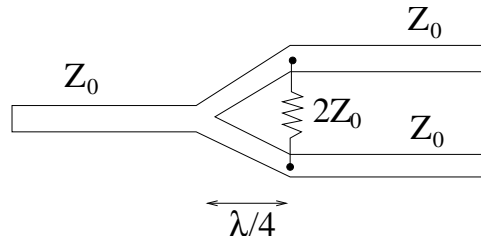

Figure 2.6: Wilkinson power divider in microstrip form. The characteristic impedance of the two quarter-wavelength branches is $\sqrt{2}Z_o$.

Analyzing this network directly to find its S-parameters would require the solution of many simultaneous equations. The amount of work required to find the S-parameters of this and other similar networks is greatly simplified by the use of the even/odd mode analysis technique.

Finding the S-parameters S_{i1} with a source at port 1 is relatively straightforward. It is more difficult to find the S-parameters with an input wave on port 2 or port 3. We will first consider the case of a source at port 2. As we will have to redraw the network several times, we will use a single wire to represent transmission lines to make the picture simpler, as shown in Fig. 2.7. This can be thought of as a microstrip circuit viewed from the top, with the other conductor for the transmission line being the ground plane.

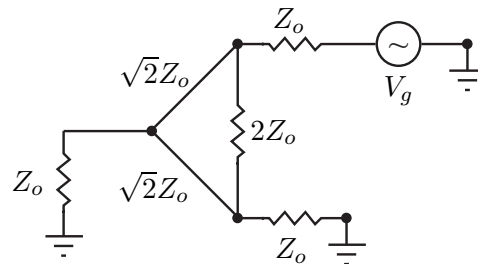

Figure 2.7: Equivalent circuit for the Wilkinson power divider.

To begin the even/odd mode analysis, we make the circuit symmetric vertically and break up the source into a sum of even and odd sources on ports 2 and 3, as in Fig. 2.8. Using superposition, we can analyze the circuit with the first pair of sources and then with the second pair. If we add the results, we have the voltages for the original single source. Because of the symmetry of the new network with even or odd sources, the analysis is much easier than is the case for the original source on port 2.

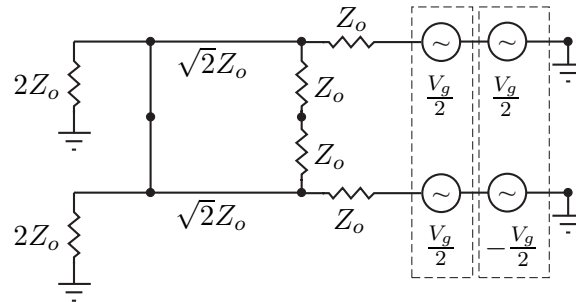

Figure 2.8: Symmetric equivalent circuit for the Wilkinson power divider.

Even Mode

For equal excitations on the output ports (2 and 3), the symmetry of the system makes it such that we have no current flowing between the upper and lower portions of the circuit. Therefore, we can treat only the top portion, recognizing that the resistor is open-circuited.

We now analyze the simplified even mode network as follows:

1. Find Z_{in}^e : For $\ell = \lambda/4$,

$$Z_{in}^e = \frac{(\sqrt{2}Z_o)^2}{2Z_o} = \frac{2Z_o^2}{2Z_o} = Z_o \tag{2.31}$$

so that port 2 is matched.

2. Find V_2^e : By voltage division,

$$V_2^e = \frac{V_g}{2} \frac{Z_{in}^e}{Z_o + Z_{in}^e} = \frac{V_g}{2} \frac{Z_o}{2Z_o} = \frac{V_g}{4} \tag{2.32}$$

3. The voltage on the $\lambda/4$ length of line is

$$V(z) = V^+ e^{-j\beta z} + V^- e^{j\beta z} \tag{2.33}$$

4. Applying the reflection coefficient at the load (left end) leads to

$$\Gamma = \frac{V^-}{V^+} = \frac{2Z_o - \sqrt{2}Z_o}{2Z_o + \sqrt{2}Z_o} = \frac{2 - \sqrt{2}}{2 + \sqrt{2}} \tag{2.34}$$

$$V(z) = V^+ \left(e^{-j\beta z} + \Gamma e^{j\beta z} \right) \tag{2.35}$$

5. This allows us to find V^+ in terms of V_g , using

$$V(-\lambda/4) = V^+ [e^{j\pi/2} + \Gamma e^{-j\pi/2}] = V^+ [j - j\Gamma] = jV^+(1 - \Gamma) \quad (2.36)$$

$$V_2^e = \frac{V_g}{4} = V(-\lambda/4) = jV^+(1 - \Gamma) \quad (2.37)$$

$$V^+ = -j \frac{V_g}{4} \frac{1}{1 - \Gamma} \quad (2.38)$$

6. Now we can get the voltage V_1^e at port 1 in terms of the source voltage:

$$V_1^e = V(0) = V^+ [1 + \Gamma] = -j \frac{V_g}{4} \frac{1 + \Gamma}{1 - \Gamma} \quad (2.39)$$

$$= -j \frac{V_g}{4} \frac{2 + \sqrt{2} + 2 - \sqrt{2}}{2 + \sqrt{2} - 2 + \sqrt{2}} = -j \frac{V_g}{4} \frac{4}{2\sqrt{2}} = -j \frac{V_g}{2\sqrt{2}} \quad (2.40)$$

Summarizing these results, we have for the even mode

$$V_1^e = -j \frac{V_g}{2\sqrt{2}} \quad (2.41)$$

$$V_2^e = \frac{V_g}{4} \quad (2.42)$$

$$V_3^e = \frac{V_g}{4} \quad (2.43)$$

where the value for V_3^e results from the symmetry of the network.

Odd Mode

For equal but opposite excitations on ports 2 and 3, the line of symmetry through the middle of the network must be an equipotential at 0 V, so we can replace the nodes at the equipotential with grounds:

We can now analyze the odd mode network:

1. Find Z_{in}^o : For $\ell = \lambda/4$

$$Z_{in}^o = \frac{(\sqrt{2}Z_o)^2}{0} = \infty \quad (2.44)$$

which is an open circuit.

2. The voltage at port 2 is

$$V_2^o = \frac{V_g}{2} \frac{Z_o}{Z_o + Z_o} = \frac{V_g}{4} \quad (2.45)$$

3. Because of the short to ground at port 1, the voltage at port 1 is zero. Because the sources at ports 2 and 3 are opposite in polarity, the voltage at port 3 is the negative of the voltage at port 2. This leads to the port voltages

$$V_1^o = 0 \quad (2.46)$$

$$V_2^o = \frac{V_g}{4} \quad (2.47)$$

$$V_3^o = -\frac{V_g}{4} \quad (2.48)$$

Superposition

We can now combine the voltages for the even and odd excitations using superposition:

$$V_1 = V_1^e + V_1^o = -j \frac{V_g}{2\sqrt{2}} \quad (2.49)$$

$$V_2 = V_2^e + V_2^o = \frac{V_g}{2} \quad (2.50)$$

$$V_3 = V_3^e + V_3^o = 0 \quad (2.51)$$

These are the voltages at each port with a source at port 2.

The input impedance at port 2 (and 3) is Z_o for both even and odd excitations. Therefore, the reflected voltage at port 2 is

$$V_2^- = V_2^{e-} + V_2^{o-} = 0 \quad (2.52)$$

This means that ports 2 and 3 are matched.

Input Match

When excited from port 1, power splits equally between branches. Therefore, no current flows in the $2Z_o$ resistor. On one branch:

$$Z_{in}^1 = \frac{(\sqrt{2}Z_o)^2}{Z_o} = 2Z_o \quad (2.53)$$

Since we see two such branches in parallel, $Z_{in}^1 = Z_o$, indicating an input match. Note that when excited from port 1, there is no power loss since no current flows through the resistor.

S-Parameter Matrix

We now use the results of the even/odd mode analysis to determine the S-parameters of the Wilkinson divider:

$$\begin{aligned}
 S_{11} &= S_{22} = S_{33} = 0 \\
 S_{32} &= \frac{V_3^-}{V_2^+} = \frac{V_3}{V_2} = 0 && \text{since } V_3 = 0 \\
 S_{23} &= 0 && \text{by symmetry} \\
 S_{12} &= \frac{V_1^-}{V_2^+} = \frac{V_1}{V_2} = -\frac{j}{\sqrt{2}} \\
 S_{21} &= S_{31} = S_{13} = -\frac{j}{\sqrt{2}}
 \end{aligned} \tag{2.54}$$

In matrix form,

$$[S] = -\frac{j}{\sqrt{2}} \begin{bmatrix} 0 & 1 & 1 \\ 1 & 0 & 0 \\ 1 & 0 & 0 \end{bmatrix} \tag{2.55}$$

If we send in signals V_2^+ and V_3^+ on ports 2 and 3, the output wave at port 1 is

$$V_1^- = -\frac{j}{\sqrt{2}}V_2^+ - \frac{j}{\sqrt{2}}V_3^+ = -\frac{j}{\sqrt{2}}(V_2^+ + V_3^+) \tag{2.56}$$

Note that the sum is scaled in magnitude by $1/\sqrt{2}$. The circuit will therefore present the sum of the two voltage signals at port 1, but with a 3 dB loss in power.

2.4 Passive Filters

Filters are an important part of microwave engineering. A filter is a two-port microwave network which attenuates signal components at some frequencies and passes others. The basic filter types are low-pass, high-pass, bandpass, and band-reject or notch filters. One approach to microwave filter design is to first come up with a low frequency lumped element design, and then map the design to transmission line sections.

2.4.1 Insertion Loss Design

A common method for specifying a filter characteristic is through the insertion loss versus frequency, or power loss ratio:

$$P_{LR}(\omega) = \frac{\text{Power available from source}}{\text{Power delivered to load}} = \frac{1}{1 - |\Gamma(\omega)|^2} \quad (2.57)$$

where Γ is the reflection coefficient looking into the input of the filter network.

For a low pass filter, one standard form for this quantity is

$$P_{LR} = 1 + k^2(\omega/\omega_c)^{2N} \quad \text{Maximally Flat/Butterworth/Binomial} \quad (2.58)$$

The loss ratio grows as frequency increases, so that high frequency components are attenuated. At the band edge ($\omega = \omega_c$), the power loss is $1 + k^2$. This filter characteristic is called maximally flat because derivatives of the response vanish at $\omega = 0$ up to order $2N$, so for a given value of N this function is as flat as possible near $\omega = 0$.

Another form for the insertion loss is

$$P_{LR} = 1 + k^2 T_N(\omega/\omega_c) \quad \text{Equal Ripple/Chebyshev} \quad (2.59)$$

where $T_N(x) = \cos(N \cos^{-1} x)$ is a Chebyshev polynomial. In the range $-1 \leq x \leq 1$, Chebyshev polynomials oscillate between ± 1 , which is where the name “equal ripple” comes from. The height of the ripples for a Chebyshev filter is $1 + k^2$. Both of these filter types have an integer order N , which is determined by the number of stages in the filter. The larger the order, the faster the rolloff of the frequency response, but the filter also becomes more expensive to implement.

Another property of a filter characteristic is linear phase, where the phase response of a filter is specified as well as the magnitude. Why would linear phase be desirable?

2.4.2 Low Pass Filter Prototypes and Transformations

For various types of filter characteristics, such as those given above for the maximally flat and equal ripple cases, lumped element values have been computed and tabulated. To save space, this is done for low pass filters only, with a corner frequency of $\omega_c = 1$ and a source impedance of $R_s = 1 \Omega$ (see Pozar, Section 8.3). If a different corner frequency or a high-pass or bandpass filter is desired, simple transformations can be applied to the low pass prototype design to get the desired filter type.

The tabulated lumped element values give capacitances and inductances for LC sections. For an N th order filter, N of these sections are cascaded to give the desired response. The response as a function of frequency is also computed (Pozar, Section 8.3), so the required value of N can be obtained from the desired attenuation at the corner frequency ω_c .

Impedance scaling. In order to scale the source impedance to R_0 , we use the transformations

$$L' = R_0 L \quad (2.60)$$

$$C' = C/R_0 \quad (2.61)$$

Frequency scaling. To change the corner frequency of a low-pass filter from unity to ω_c , we replace ω in the impedances of the lumped elements with $\omega \rightarrow \omega/\omega_c$. This leads to the transformations

$$L'' = L'/\omega_c \quad (2.62)$$

$$C'' = C'/\omega_c \quad (2.63)$$

Low-pass to high-pass transformation. To change a low-pass filter prototype into a high-pass filter, we make the replacement $\omega \rightarrow -\omega_c/\omega$. This leads to

$$L'' = \frac{1}{\omega_c C'} \quad (2.64)$$

$$C'' = \frac{1}{\omega_c L'} \quad (2.65)$$

Low-pass to bandpass transformation. To change a low-pass filter prototype into a band-pass filter, we use

$$\omega \rightarrow \frac{1}{\Delta} \left(\frac{\omega}{\omega_0} - \frac{\omega_0}{\omega} \right) \quad (2.66)$$

where $\Delta = (\omega_2 - \omega_1)/\omega_0$ and the corners of the passband are ω_1 and ω_2 . The center frequency is often chosen to be $\omega_0 = \sqrt{\omega_1 \omega_2}$. For the bandpass filter, the element transformations are a little more complicated. A series inductance L' is transformed into a series LC circuit with

$$L'' = \frac{L'}{\Delta \omega_0} \quad (2.67)$$

$$C'' = \frac{\Delta}{\omega_0 L'} \quad (2.68)$$

and a shunt capacitance C' is transformed into a shunt LC circuit with

$$L'' = \frac{\Delta}{\omega_0 C'} \quad (2.69)$$

$$C'' = \frac{C'}{\Delta \omega_0} \quad (2.70)$$

This should be intuitive, because an inductor is a low-pass filter, and an LC circuit is a bandpass filter with the band center at the resonance frequency.

2.4.3 Implementation

The capacitors and inductors resulting from the low-pass prototype approach can be realized using either lumped elements or transmission line sections.

Other methods for implementing microstrip filters are stepped-impedance filters, consisting of alternating sections of low impedance and high impedance lines, and coupled line filters, which are sections of transmission lines placed nearby with frequency dependent coupling between the lines.